

# Pneumatic Rack & Pinion Actuators and Accessories

Reliable actuators to “Fit and Forget”



**EL-O-MATIC™**

  
**EMERSON™**  
Process Management



**El-O-Matic** is renowned as an industry benchmark for delivering the range of features and benefits required from a rack & pinion actuator

A proven track record of over 35 year's service in over 2 Million applications

High reliability offering second to none service levels

A flexible modular package offering multiple configurations and \$/torque value for money

## Optimum performance

As a manufacturer, Emerson Process Management - Valve Automation realise that performance of our pneumatic actuators is vitally important to your production process. An actuator that does not function well can have serious consequences for the outcome of the process which can cost you dearly in down-time and loss of production. That is why for over 35 years and well over two million actuators produced, reliability has been our primary concern in actuator development. **El-O-Matic** pneumatic actuators are manufactured to worldwide industry standards and directives that ensures the production of reliable, quality products, continuously providing the optimum "Fit and Forget" performance to a wide range of end-user applications in process industries such as Chemical, Refining, Power Generation, Pulp & Paper and the utilities areas of Pharmaceuticals and Food & Beverage.

**El-O-Matic** ¼ turn rotary actuators have a unique cast aluminium alloy body and a two component polyurethane paint finish, ensuring many years of faithful performance against harsh environments. In addition, actuators are built inclusive of features that are well proven in their required application environments.

### Application and Features

For use on ball, plug and butterfly valves.

- Compact rack & pinion design.
- Choice of thirteen sizes, with a torque range from 12 Nm to 4000 Nm (106 in/lbs to 36,474 in/lbs)
- Also used in other ¼ turn applications, such as dampers and pressure regulators.
- High duty aluminium alloy provides optimum strength and corrosion resistance.
- Can be supplied in single (spring return) or double acting versions.
- Mounting for solenoid valves and position signallers to the NAMUR standard (VDI / VDE 3845).
- Valve mounting and drive dimensions to the ISO 5211 or DIN 3337 standard.
- Pinion provided with removable insert for low cost, versatile, direct mounting to valve stem.
- Pinion with anti blow-out design.

### Operating principle

Both the double acting and single acting (spring return) versions of these pneumatic actuators are designed in such a way that there are no moving parts on the outside (with the exception of the position indicator). This makes them safe, easy to install and virtually maintenance free.

Furthermore, the compact rack and pinion construction means that actuators are lightweight and occupy a minimum of space, allowing users to install them in any orientation between close pipe configurations.



### Ample choice of spring packages

Spring return, single acting actuators are used in the majority of systems as a fail-safe method of either closing or opening the valve to suit the application. Their ability to automatically return the valve to its fail-safe position upon air failure provides the vital link for ultimate system safety and shut down. El-O-Matic spring return actuators contain modular spring cartridges, which enable them to be easily configured, by adding or subtracting individual

springs, to provide combinations that cover a wide variety of torque capabilities under different supply pressures and operating parameters.



## Application



The choice of actuator size depends primarily on the torque requirement of the valve

and with El-O-Matic you have the wide choice of 13 basic model sizes covering a torque range from 12 Nm to 4000 Nm. (106 in/lbs to 36,474 in/lbs)

However for optimum actuator sizing many factors may need consideration, so to provide the best "Fit and Forget" option, the El-O-Matic range is matched against all available relevant technical data on the majority of major quarter-turn valve manufacturers in the world. This electronic database enables us to select just the right actuator for you, whatever the valve type: ball, butterfly or plug valve.

## Long life span

The 3-point guiding system of the enclosed pistons allows for a smooth operation with the aid of fully synthetic bearings and a rack & pinion gearing. The high precision gear cutting methods provide close tolerances between the rack and pinion teeth to ensure minimum gear backlash and avoid mechanical hysteresis, all of which helps limit-switch point accuracy and contributes to a very long working life. El-O-Matic actuators are guaranteed to perform in high cycle applications according to the CEN standard exceeding 500,000 cycles, and perform extremely well in comparison to any rack and pinion actuator in the industry.

## Inserts

All actuator sizes up to 1600 Nm are fitted with removable drive inserts, to accommodate different valve stem profiles. This enables actuators to be directly mounted on to suitable valves and eliminates the need for a bracket and coupling type mounting kit. The use of direct mount inserts significantly cuts the cost of the valve / actuator assembly. Standard actuators are fitted with square drive inserts in accordance with ISO 5211 (or DIN 3337 as required) but a wide variety of other inserts are also available. Special inserts may have oversize or undersize squares or made with double-D profile or shaft key-way forms. These can be supplied on factory built actuators or as separate spare part items. Drive inserts are easily replaceable at distributor or end user level.



Where direct mounts are not possible, for instance on valves with exposed gland packing or high bonnets, the use of inserts often simplifies the design of the mounting kit, saving time and money in installation.

## Limit stops

A limit stop bolt, used for switch setting, is necessary where the open position of the valve requires precise adjustment. These are standard on all actuators up to 1600 Nm. and optional on the two larger sizes. Actuators with double stroke adjustment are also available for those applications on high performance butterfly valves, for example, to ensure confirmation of the closed position.

## Standardisation

El-O-Matic actuators comply fully with all the relevant industry standards for interfaces and connections. Control interfaces for solenoid valves, switch boxes and position controllers satisfy the NAMUR standard (VDI / VDE 3845). Valve mounting and drive dimensions conform to the ISO 5211 standard (with an option for DIN 3337).

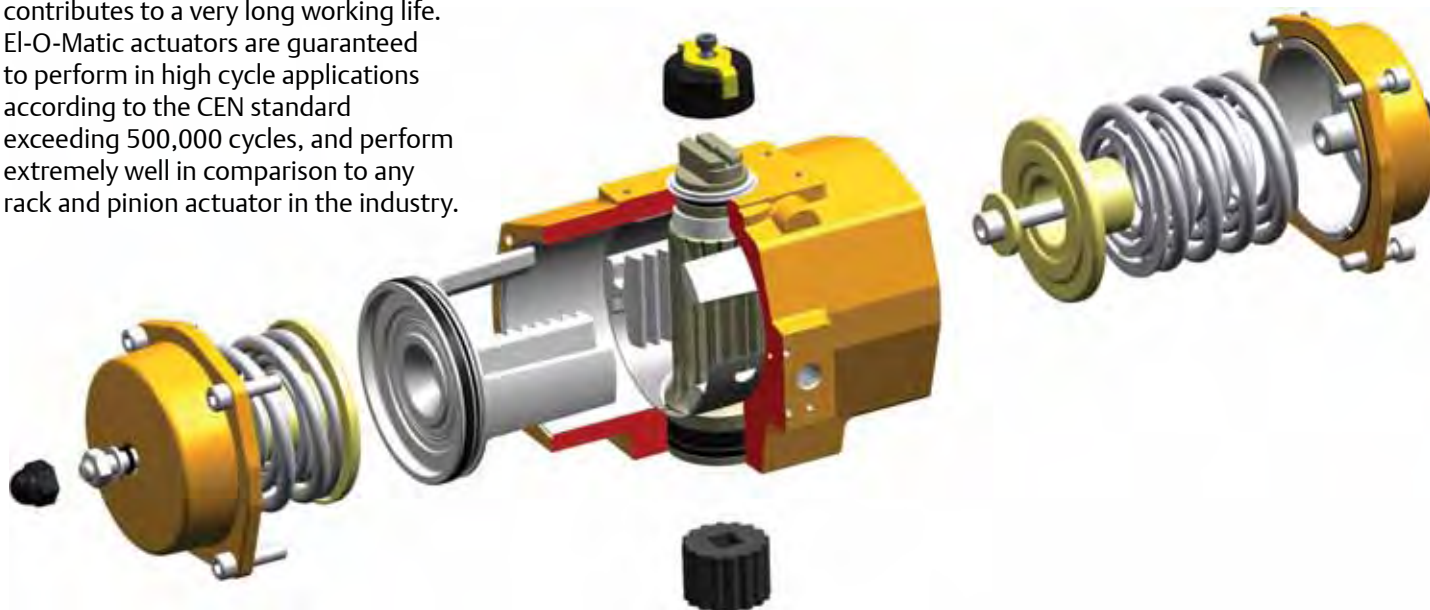

# Design and construction based on the “Fit and Forget” Principles

## Fit and forget - Reliability

One of the main-stay’s in the development of our El-O-Matic actuator product is the “Fit and Forget” principle: Reliability is key to customer satisfaction and so actuators and their accessories must be quick and easy to install and function faultlessly through a long working life. This is made possible by the high degree of modular construction in our products, ensuring that mass produced components are made to a high degree of quality assurance and comply with ISO 9001.

## Fit and Forget - Innovation

While El-O-Matic was traditionally a manufacturer of only actuators, Emerson’s Valve Automation business strives to maintain the brand in a leadership position by the introduction of new developments to support the “Fit and Forget” principle. Our policy continues to be focused on the supply of all the automation components located between the hardware of the valve and the software of the process-control system. This means a continuous activity of updates, new development and product innovation.

## Fit and Forget - Modular construction

Our actuators and accessories are mainly made up of standard components. This means that they can be assembled and delivered fast in a variety of frequently used configurations. In order to meet new and ever demanding market requirements, our products are the subject of continuous refinement, adapting to multiple industry applications.

## Fit and Forget – Proven Track Record

Based on proven technology with an installed base of over two million actuators worldwide the El-O-Matic brand is well recognised as the industry ‘benchmark’ for a multitude of process industry applications. The robust, corrosion resistance design offers an easy to install actuator which functions faithfully giving many years of dependable performance.

## Fit and Forget - Comprehensive offering

With single and double acting actuator in 13 sizes, ranging from 12 Nm to 4100 Nm (106 in/lbs to 36,474 in/lbs), El-O-Matic offers an even more versatile and competitive actuator range giving excellent \$/torque value.

## Fit and Forget - Cost effectiveness

Standardised mounting interfaces offer easy valve and accessory assembly. Dual valve flange drilling patterns and an interchangeable insert drive system allows for direct mounting capability, reduces the need for maintenance and increasing plant efficiency.

El-O-Matic E and P series actuators means:

### More

Process reliability  
Plant up-time  
Plant and operator safety

### Lower

Capital cost  
Assembly cost  
Installation cost  
Maintenance cost

## El-O-Matic Actuator Range

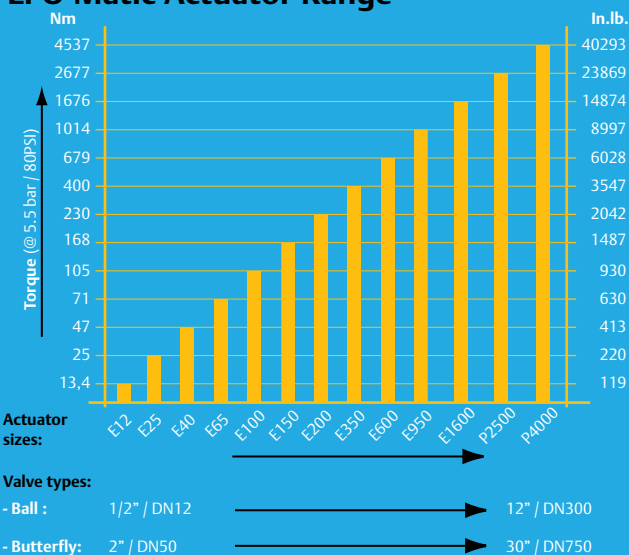

## Specifications:

Pressure:	Double acting	0.2 to 8 Barg	(3 to 116 Psig)
	Spring return	3 to 8 Barg	(43.5 to 116 Psig)
Temperature:	Standard	-20°C to +80°C	(-4°F to +176°F)
	High Temp.	-20°C to +120°C	(-4°F to +248°F)
	Low Temp.	-40°C to +80°C	(-40°F to +176°F)
Materials:	Housing:	Aluminium alloy.	
	Pinion:	Hard anodised aluminium alloy.	
Finish:	Polyester non-TGIC based powder coating.		
Life span:	Minimum of 500.000 cycles.		

For more detailed technical information see our online documentation under [www.El-O-Matic.com](http://www.El-O-Matic.com). Document number [DOC.DSE.PN.UK]

## Actuator / Accessory interfaces

El-O-Matic actuators can be packaged together with a range of accessories including;



El-O-Matic actuators with TopWorx accessories



Wireless transmitter



Solenoids



Pressure Regulators



Digital valve positioners (DVC's)



Manual override gear-boxes

In addition, these accessories often include dedicated options like;



Speed control plates



Breather blocks



Block & bleed valves

All of the above fit together by way of standard product interfaces such as NAMUR for solenoid and switch box connections and ISO-5211 for valve flange connections. Using these well known international standards ensures that El-O-Matic products will comply with application requirements in projects worldwide

Emerson Process Management - Valve Automation is pleased to confirm their association with these other famous Emerson brands as the most commonly requested actuator accessories:

Fisher – Position Controller's (DVC's)

Fisher - Regulators

Fisher – TopWorx switch boxes

Asco Numatics – Solenoid valves

EL-O-Matic actuators are manufactured to these worldwide standards as follows;

**Safety Standards**



**Product Interface Standards**

VDI/VDE3845 (NAMUR)  
ISO – 5211

**Company Operations Standards**

ISO – 9001 Quality Assurance

**Contact Us: Emerson Process Management, Valve Automation facilities at your nearest location:**

**NORTH & SOUTH AMERICA**

18703 GH Circle  
PO Box 508  
Waller, TX 77484  
USA  
T +1 281 727 5300  
F +1 281 727 5353

2500 Park Avenue West  
Mansfield, OH 44906  
USA  
T +1 419 529 4311  
F +1 419 529 3688

9009 King Palm Drive  
Tampa, FL 33619  
USA  
T +1 813 630 2255  
F +1 813 630 9449

13840 Pike Road  
Missouri City, Texas 77489  
USA  
T +1 281 499 1561  
F +1 281 499 8445

Av. Hollingsworth,  
325, Iporanga Sorocaba,  
SP 18087-105  
Brazil  
T +55 15 3238 3788  
F +55 15 3228 3300

**MIDDLE EAST & AFRICA**

P. O. Box 17033  
Dubai  
United Arab Emirates  
T +971 4 811 8100  
F +971 4 886 5465

P. O. Box 105958  
Abu Dhabi  
United Arab Emirates  
T +971 2 697 2000  
F +971 2 555 0364

P. O. Box 3911  
Al Khobar 31952  
Saudi Arabia  
T +966 3 814 7560  
F +966 3 814 7570

P. O. Box 10305  
Jubail 31961  
Saudi Arabia  
T +966 3 340 8650  
F +966 3 340 8790

P. O. Box 32281  
Doha  
Qatar  
T +974 4 576777  
F +974 4 315448

2 Monteer Road, Isando  
Kempton Park, 1600  
South Africa  
T +27 11 974 3336  
F +27 11 974 7005

**EUROPE**

Asveldweg 11  
7556 BR Hengelo (O)  
The Netherlands  
T +31 74 256 1010  
F +31 74 291 0938

Siemensring 112  
47877 Willich  
Germany  
T +49 2154 499 660  
F +49 2154 499 6613

25, Rue de Villeneuve  
Silic – BP 40434  
94583 Rungis  
France  
T +33 1 49 79 73 00  
F +33 1 49 79 73 99

Via Montello 71/73  
20038 Seregno (Milan)  
Italy  
T +39 0362 2285 207  
F +39 0362 2436 55

6 Bracken Hill  
South West Industrial Estate  
Peterlee SR8 2LS  
United Kingdom  
T +44 191 518 0020  
F +44 191 518 0032

2A Szturmowa Str  
02-678 Warsaw  
Poland  
T +48 22 4589 237  
F +48 22 4589 231

C/ Francisco Gervás, 1  
28108 Alcobendas – Madrid  
Spain  
T +34 0913 586 000  
F +34 0913 589 145

Letnikovskaya Str. 10-2  
115114 Moscow  
Russia and FSU  
T +7 495 981 98 11  
F +7 495 981 98 10

**ASIA PACIFIC**

No. 9 Gul Road  
#01-02 Singapore 629361  
T +65 6501 4600  
F +65 6268 0028

9/F Gateway Building  
No. 10 Ya Bao Road  
Chaoyang District  
Beijing 100020  
P.R.China  
T +86 10 5821 1188  
F +86 10 5821 1100

No.15 Xing Wang Road  
Wuqing Development Area  
Tianjin 301700  
P.R.China  
T +86 22 8212 3300  
F +86 22 8212 3308

Lot 13112, Mukim Labu  
Kawasan Perindustrian Nilai  
71807 Nilai, Negeri Sembilan  
Malaysia  
T +60 6 799 2323  
F +60 6 799 9942

471 Mountain Highway  
Bayswater, Victoria 3153  
Australia  
T +61 3 9721 0200  
F +61 3 9720 0588

Delphi B Wing, 601 & 602  
6th Floor, Central Avenue  
Powai, Mumbai – 400 076  
India  
T +91 22 6662 0566  
F +91 22 6662 0500

NOF, Shinagawa Konan Bldg  
1-2-5, Higashi-shinagawa  
Shinagawa-ku, Tokyo  
140-0002 Japan  
T +81 3 5769 6873  
F +81 3 5769 6902

© 2009 Emerson Process Management. All rights reserved.

The Emerson logo is a trademark and service mark of Emerson Electric Co. "Brand mark listing" are marks of one of the Emerson Process Management family of companies. All other marks are property of their respective owners.

The contents of this publication are presented for information purposes only, and while every effort has been made to ensure their accuracy, they are not to be construed as warranties or guarantees, express or implied, regarding the products or services described herein or their use or applicability. All sales are governed by our terms and conditions, which are available on request. We reserve the right to modify or improve the designs or specifications of our products at any time without notice.

EL-O-MATIC® is a registered trademark of EL-O-MATIC B.V.